

THIS DRAWING IS THE PROPERTY OF BROWNELL LTD. AND MAY NOT BE COPIED OR REPRODUCED WITHOUT THEIR PRIOR WRITTEN PERMISSION

DRG No
BL/D3722 INST

USED ON -

REMOVE ALL SHARP EDGES UNLESS SPECIFIED

THIRD ANGLE PROJECTION

DO NOT SCALE - ASK

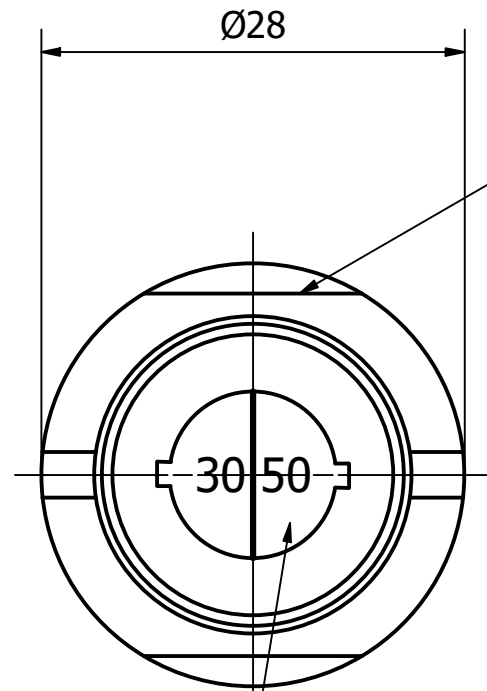

SPANNER FLATS

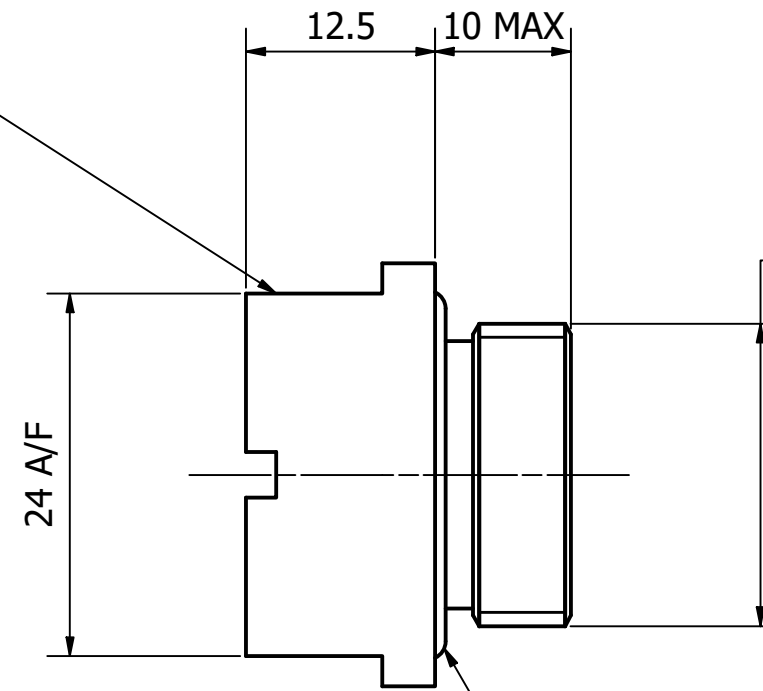

M20 x 1.5 - 6g
NATURAL FINISH
FOR R.F. SCREENING
CONTINUITY

HUMIDITY INDICATOR DISC CHANGES
COLOUR AT APPROX 30% & 50% RH
AT 25°C (SPLIT LEVEL)

EPDM 'O' SEAL

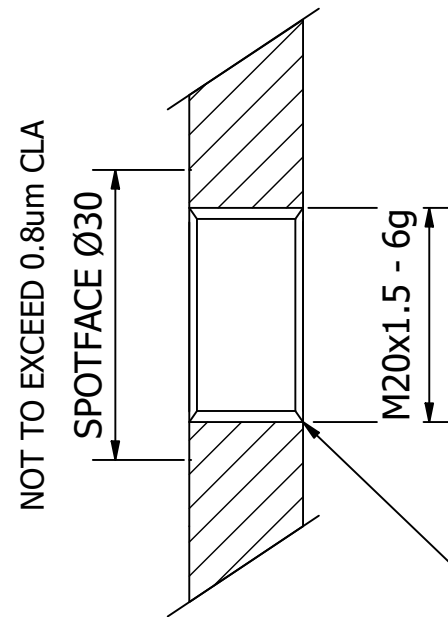

THREAD RELIEF NOT TO
EXTEND BEYOND MAJOR
DIAMETER OF THREAD
MUST BE UNPLATED FINISH

NOTES:

INTERNAL THREAD M16x1 - 6H TO FIT VARIOUS SILICA
GEL FILLED DESICCANT CONTAINERS DEHUMIDIFIER

THE ITEM IS PACKAGED FOR A 5 YEAR TEMPERATE OR
3 YEAR TROPICAL SHELF LIFE IN MFL EITHER
INDIVIDUALLY OR ENVELOPES HOLDING 3

THREAD FINISH CHANGED	7180	6	10/02/20
REDRAWN	5882	5	11/01/02
LETTER 'M' DELETED	5381	4	18/01/99
IND LEVELS ADDED	3271	3	04/08/87
	2681	2	29/02/84
ORIGINAL		1	04/10/82
CHANGE	MOD No	ISSUE	DATE

PANEL MOUNTING DETAIL

MATERIAL ALUMINIUM ALLOY	PROTECTIVE FINISH BLACK ANODISED & NATURAL THREAD	UNLESS OTHERWISE STATED	ANGULAR DIMS ± 0.5°	LINEAR DIMS 0 = ± 0.5 0.0 = ± 0.25 0.00 = ± 0.05	BROWNELL Ltd. LONDON NW10 7XF	RED DOT=ORIGINAL BLACK DOT=COPY	DRAWN SKS	CHECKED RB
EST. WT. ----		SURFACE ROUGHNESS 3.2 µm (N8)		TITLE		DRAWING NUMBER		
		DIMENSIONS IN in/mm		INDICATOR HUMIDITY PLUG R.F. SCREENED STYLE RIHP3M - DEF STAN 66-14 6685-99-225-3311		BL/D3722 INST		
		SCALE (ORIGINAL)		2:1				